

THIS DRAWING IS UNPUBLISHED. RELEASED FOR PUBLICATION
 © COPYRIGHT BY TYCO ELECTRONICS CORPORATION. ALL RIGHTS RESERVED.

LOC	DIST	REVISIONS					
DF	X5	P	LTR	DESCRIPTION	DATE	DWN	APVD
		L		REV PER ECO 06-01723	1-23-06	CT	BM

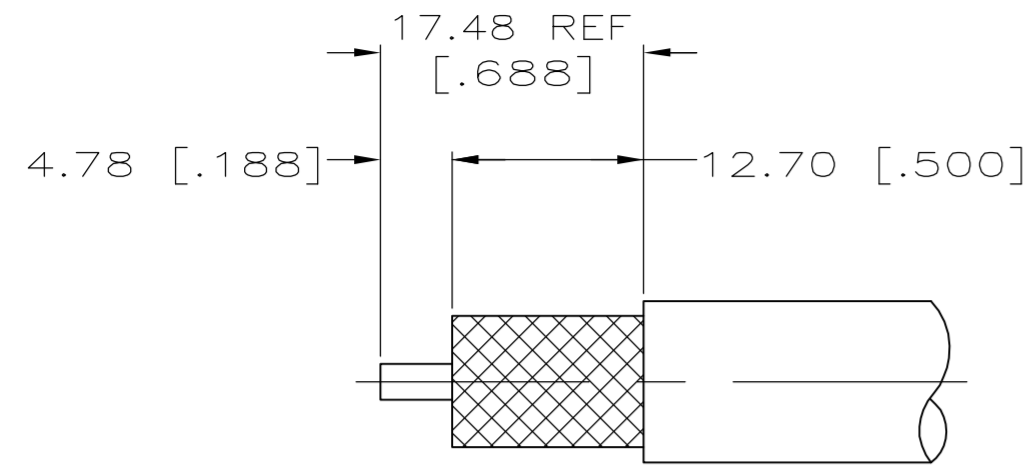

VIEW X
RECOMMENDED STRIP LENGTH

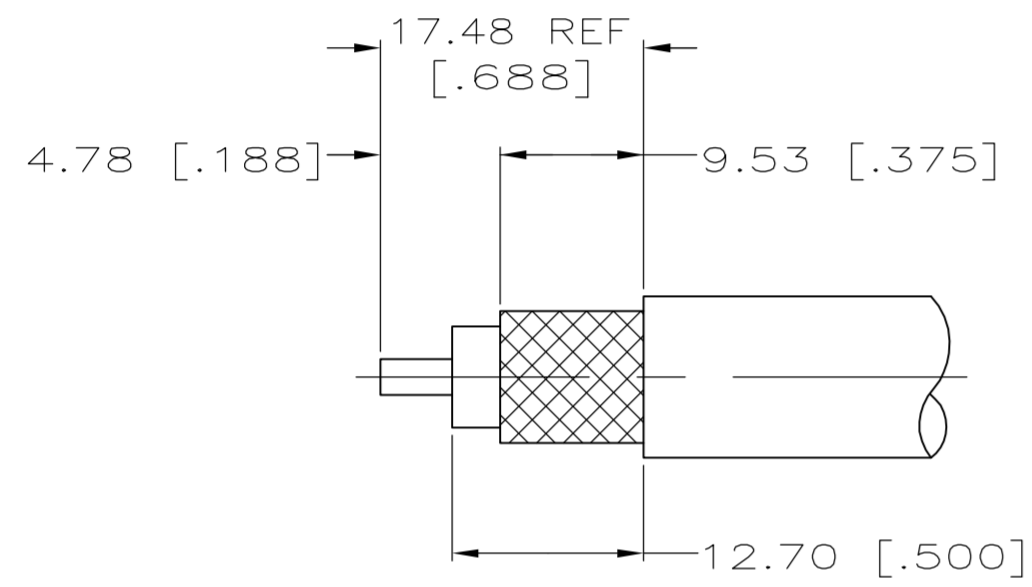

VIEW Y
RECOMMENDED STRIP LENGTH

- 1. PARTS PACKAGED UNASSEMBLED.
- 2. THREE SAFETY WIRE HOLES $\varnothing 0.61$ [.024] MINIMUM, EQUALLY SPACED AROUND CIRCUMFERENCE.
- 3. SEE INSTRUCTION SHEET #2028-5.
- 4. OBSOLETE PART NUMBER.
- 5. SUPERSEDED BY 225389-4.

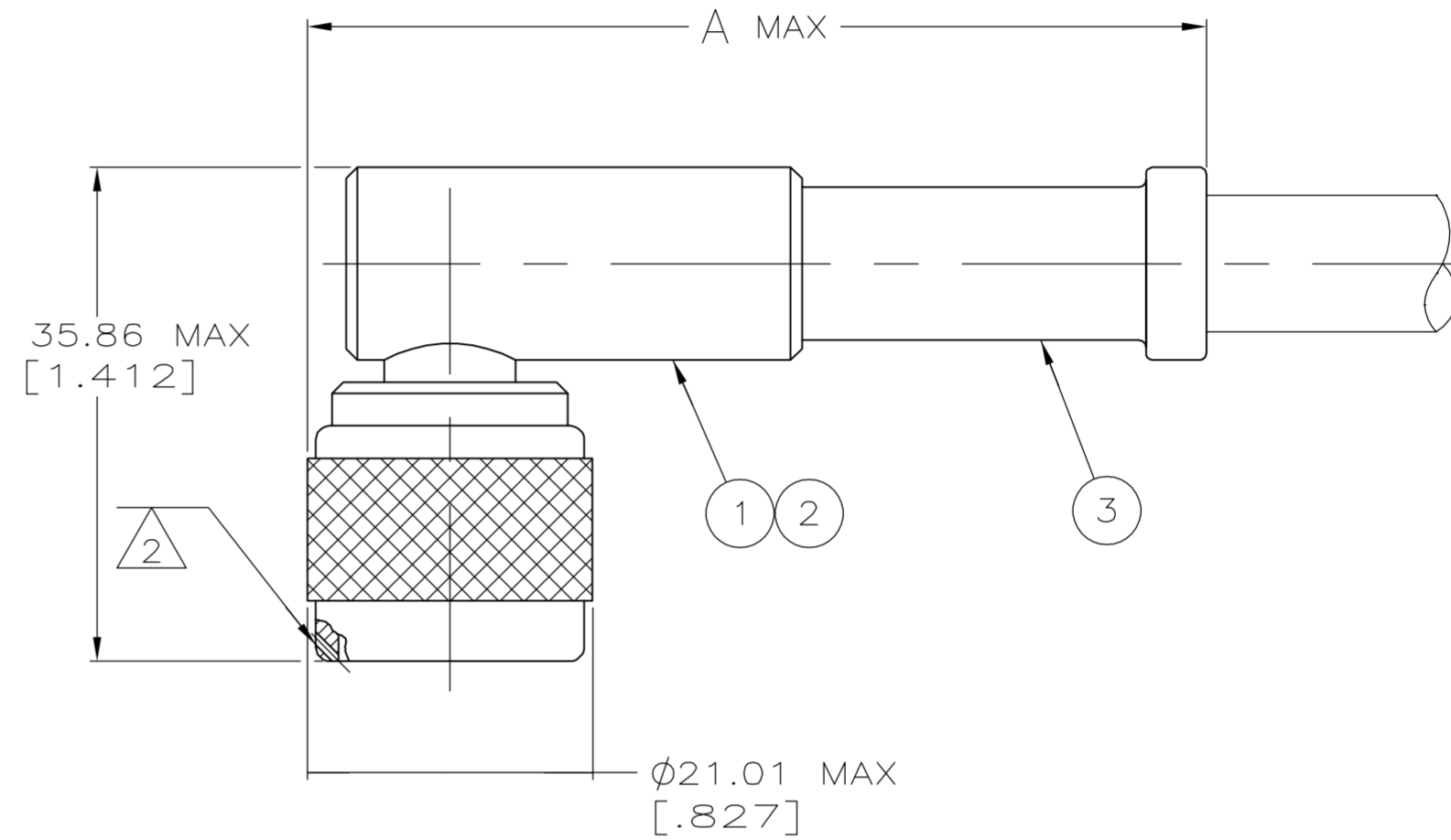

-	-	-	-	-	-	-	-	5 7-225389-4
RG-213/U	7-225389-2 AMP	220015-1	62.31 [2.453]	Y	1-331987-3	51704-2	225417-1	7-225389-2
RG-225/U	5-225389-3 TYCO	220015-1	62.31 [2.453]	X	1883158-1	1-51704-0	1883152-1	5-225389-3
-	-	-	-	-	-	-	-	4 1-225389-0
MICRODOT 250-4172 & 250-4208	225389-9 AMP	220015-3	61.49 [2.421]	Y	225612-2	51704-2	225904-1	225389-9
RG-165/U & M15224	225389-8 AMP	220015-1	62.31 [2.453]	Y	1-331987-3	1-51704-0	225417-1	225389-8
RG-393/U	225389-6 AMP	220015-1	62.31 [2.453]	X	225490-1	1-51704-0	225417-1	225389-6
RG-214/U	10688467 AMP	220015-1	62.31 [2.453]	X	331987	51704-2	225417-1	4 225389-5
RG-214/U	00779 M39012/05B0003 AMP & DATE CODE	220015-1	62.31 [2.453]	X	331987	51704-2	225417-1	4 225389-4
RG-225/U	225389-3 AMP	220015-1	62.31 [2.453]	X	331987	1-51704-0	225417-1	225389-3
RG-213/U	00779 M39012/05B0002 AMP & DATE CODE	220015-1	62.31 [2.453]	Y	1-331987-3	51704-2	225417-1	225389-2
RG-115A/U	225389-1 AMP	220015-1	62.31 [2.453]	X	1-331987-3	51704-2	225417-2	4 225389-1
CABLE SIZE	STAMPING	CRIMP TOOL	A	VIEW	3 FERRULE QTY=1	2 CONTACT QTY=1	1 PLUG ASSY QTY=1	PART NUMBER

10-30-91
 THIS DRAWING IS A CONTROLLED DOCUMENT.
 10-30-91
 M. SNEED
 TOLERANCES UNLESS OTHERWISE SPECIFIED:
 0 PLC ± -
 1 PLC ± -
 2 PLC ± 0.41 [.016]
 3 PLC ± -
 4 PLC ± -
 ANGLES ± -
 MATERIAL -----
 FINISH -----

DWN B. SCOTT 5-29-91
 CHK M. SNEED 10-30-91
 APVD M. SNEED 10-31-91
 PRODUCT SPEC 108-12019
 APPLICATION SPEC -
 WEIGHT 2.6 OZ MAX
 CUSTOMER DRAWING

AMP Tyco Electronics Corporation
 Harrisburg, PA 17105-3608
 NAME PLUG, RIGHT ANGLE, WEATHERPROOF, SERIES N
 SIZE A2 CAGE CODE 00779 DRAWING NO C=225389 RESTRICTED TO -
 SCALE 2:1 SHEET 1 of 1 REV L